

### HM150 Series



#### HM150-EXT-BAR

Extend your canopy and increase your yield with HM150 extension bars. Easy to install on HM660 or HM960. Select your desired spacing, hang the driver on the light frame, and plug each side into the extra ports on the driver housing. HM150 will dim accordingly with your HM660/HM960.



#### FEATURES & BENEFITS

- Compatible with GrowPros Solutions HM660 or HM960
- Extension bars on each side add 1' x 4' to your canopy
- Easy to install and connect to HM660 or HM960
- Multiple spacing configurations
- Sold as a pair

#### TECHNICAL SPECIFICATIONS

WATTAGE	<b>150W (each bar)</b>
INPUT POWER	<b>120V-277V</b>
FREQUENCY	<b>50/60Hz</b>
CONTROL	<b>intergrated with HM660 + HM960</b>
POWER FACTOR	<b>0.9</b>
THD	<b>20%</b>
WORKING TEMPERATURE	<b>-40°F ~ 122°F</b>
IP RATING	<b>IP44, Suitable for dry &amp; damp locations</b>
WARRANTY	<b>7 year limited</b>

PERFORMANCE DATA	MAX. POWER
PPF	<b>368 µmol/s</b>
PPE	<b>2.7 µmol/J</b>

#### HEAT LOAD

HEAT LOAD PER PAIR	<b>1,025 BTU</b>
--------------------	------------------

#### MAXIMUM POWER ELECTRICAL DATA (each bar)

AC VOLTAGE	120V	208V	240V	277V
AC CURRENT	<b>1.25A</b>	<b>.72A</b>	<b>.625A</b>	<b>.54A</b>
AC POWER	<b>150W</b>	<b>150W</b>	<b>150W</b>	<b>150W</b>

#### SPECTRAL DISTRIBUTION

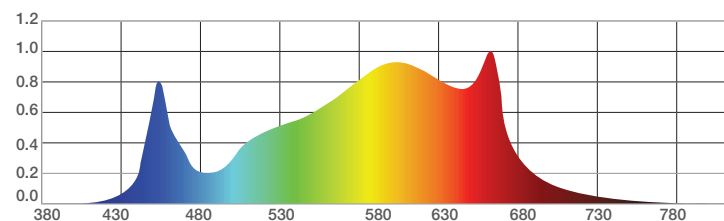

#### DIMENSIONS

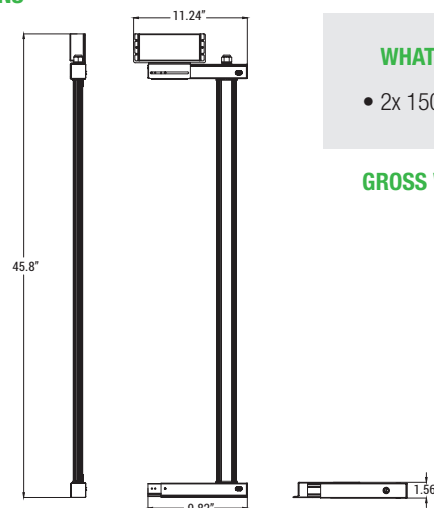

#### WHAT'S IN THE BOX

- 2x 150W Extension Bars

**GROSS WEIGHT: 8.82 lbs**